

# RECOMMENDED FASTENERS FOR WAFER-SPHERE® BUTTERFLY VALVES

The tables on the following pages provide information regarding the size, type, and quantity of fasteners recommended for installing Wafer-Sphere high-performance butterfly valves into a piping system. They are intended as a planning and procurement guide. For actual installation, please refer to the "Installation, Maintenance & Operating Instructions" provided with each individual product. The general notes below should be reviewed and considered when planning fastener purchases.

## 1. FASTENER THREADS

Fasteners with Class 2A threads are recommended. Fastener diameters less than 1-1/8" (28.6 mm) have UNC series threads, and 1-1/8" (28.6 mm) and larger have 8-UN series threads.

## 2. MACHINE BOLTS

The use of machine bolts to install butterfly valves between flanges is not recommended. Machine bolt length and flange thickness tolerance variations could result in "bottoming out" of the bolt before full gasket compression, or insufficient thread engagement.

## 3. NUTS

Standard heavy hex nuts per ANSI B18.2.2 with class 2B threads are recommended. All studs require one nut each, and stud-bolts require two nuts each.

## 4. SHORT STUDS

Many Wafer-Sphere valves have tapped holes adjacent to the shaft and/or adjacent to tapped lifting lugs. These tapped holes require short flange fasteners (short studs). Required short studs are noted in the following tables.

## 5. "DEAD END" SERVICE

When lugged valves are connected to only a single flange, and a mating flange is not installed, fasteners are required on only one side of the body. Use half of the quantities listed.

## 6. THREAD ENGAGEMENT

Length of thread engagement is in accordance with ANSI B31.3 (Chemical Plant & Petroleum Refinery Piping). Stud-bolt and stud lengths herein are effective thread lengths and do not include the end points. Machine bolt lengths include the end point.

## 7. GASKET THICKNESS

Fastener lengths are based on installation of the valve between standard raised face flanges, utilizing flange gaskets with a final compressed thickness of 1/8" (3.2 mm). To maintain thread engagement per note 6, adjust fastener lengths and/or install washers as necessary when using gaskets that have a final compression thickness of less than, or greater than 1/8" (3.2 mm).

## 8. MATING FLANGES

Fastener lengths and quantities are based on installation with flanges in accordance with ANSI B16.5 on valve sizes through 24" (DN 600) valves, and MSS-SP-44 for sizes larger than 24" (DN 600).

## 9. 3" (DN 80) AND 4" (DN 100) 830W BETWEEN CLASS-150 FLANGES

When installing 3" (DN 80) and 4" (DN 100) Type 830W valves between ANSI Class 150 flanges, use the stud-bolts recommended for the corresponding Type 815W valve.

Valve Size		Fastener Diameter & Thread	Type 815W, Wafer Body					Type 815L, Lugged Body			
inches	DN		Quantity		Length - inches			Quantity	Length - inches		
			No. of "A" Stud-Bolts	No. of "B" Studs or "C" Machine Bolts	Stud-Bolt Length (A)	Short Stud Length (B)	Machine Bolt (C)	No. of "C" Machine Bolts or "D" studs	Machine Bolt Length (C)	Stud Length (D)	
2-1/2	60	5/8" - 11UNC	4	—	5-3/4	—	—	8	1-3/4	2-1/2	
3	80	5/8" - 11UNC	4	—	5-3/4	—	—	8	1-3/4	2-1/2	
4	100	5/8" - 11UNC	8	—	6	—	—	16	1-3/4	2-1/2	
5	125	3/4" - 10UNC	8	—	6-1/2	—	—	16	2	2-3/4	
6	150	3/4" - 10UNC	8	—	6-1/2	—	—	16	2	3	
8	200	3/4" - 10UNC	8	—	7	—	—	16	2-1/4	3	
10	250	7/8" - 9UNC	12	—	7-1/2	—	—	24	2-1/2	3-1/4	
12	300	7/8" - 9UNC	12	—	8	—	—	24	2-1/2	3-1/2	
14	350	1" - 8UNC	12	—	9	—	—	24	2-3/4	3-3/4	
16	400	1" - 8UNC	16	—	9-1/2	—	—	32	2-3/4	3-3/4	
18	450	1-1/8" - 8UN	16	—	10-1/2	—	—	32	3	4-1/4	
20	500	1-1/8" - 8UN	16	8	11-1/2	4-1/2	3-1/4	40	3-1/4	4-1/2	
24	600	1-1/4" - 8UN	16	8	13-1/4	4-3/4	3-1/2	40	3-1/2	4-3/4	
30	750	1-1/4" - 8UN	20	16	15-3/4	6	4-1/2	56	4-1/2	6	
36	900	1-1/2" - 8UN	24	16	18-1/2	7	5-1/2	64	5-1/2	7	
42	1050	1-1/2" - 8UN	28	16	20-1/2	7-1/4	5-3/4	72	5-3/4	7-1/4	
48	1200	1-1/2" - 8UN	36	16	22-1/2	7-3/4	6-1/4	88	6-1/4	7-3/4	
54	1350	1-3/4" - 8UN	36	16	24-1/2	8-3/4	7	88	7	8-3/4	
60	1500	1-3/4" - 8UN	44	16	26-1/2	9	7-1/2	104	7-1/2	9	

Valve Size		Fastener Diameter & Thread	Type 830W, Wafer Body					Type 830L, Lugged Body			
inches	DN		Quantity		Length - inches			Quantity	Length - inches		
			No. of "A" Stud-Bolts	No. of "B" Studs or "C" Machine Bolts	Stud-Bolt Length (A)	Short Stud Length (B)	Machine Bolt (C)	No. of "C" Machine Bolts or "D" studs	Machine Bolt Length (C)	Stud Length (D)	
2-1/2	65	3/4" - 10UNC	8	—	6-1/2	—	—	16	2-1/4	3	
3	80	3/4" - 10UNC	8	—	6-1/2	—	—	16	2-1/4	3	
4	100	3/4" - 10UNC	8	—	6-3/4	—	—	16	2-1/4	3-1/4	
5	125	3/4" - 10UNC	8	—	7	—	—	16	2-1/2	3-1/4	
6	150	3/4" - 10UNC	12	—	7-1/2	—	—	24	2-1/2	3-1/4	
8	200	7/8" - 9UNC	12	—	8-1/2	—	—	24	2-3/4	3-3/4	
10	250	1" - 8UNC	12	8	9-3/4	4-1/4	3-1/4	32	3-1/4	4-1/4	
12	300	1-1/8" - 8UN	12	8	10-1/2	4-3/4	3-1/2	32	3-1/2	4-3/4	
14	350	1-1/8" - 8UN	16	8	11-3/4	4-3/4	3-3/4	40	3-3/4	4-3/4	
16	400	1-1/4" - 8UN	16	8	13	5-1/4	4	40	4	5-1/4	
18	450	1-1/4" - 8UN	20	8	14	5-1/4	4	48	4	5-1/4	
20	500	1-1/4" - 8UN	20	8	14-3/4	5-1/2	4-1/4	48	4-1/4	5-1/2	
24	600	1-1/2" - 8UN	20	8	16-3/4	6-1/4	4-3/4	48	4-3/4	6-1/4	
30	750	1-3/4" - 8UN	24	8	22-1/2	7-1/2	6	56	6	7-1/2	
36	900	2" - 8UN	28	8	24-1/2	8-1/2	6-3/4	64	6-3/4	8-1/2	

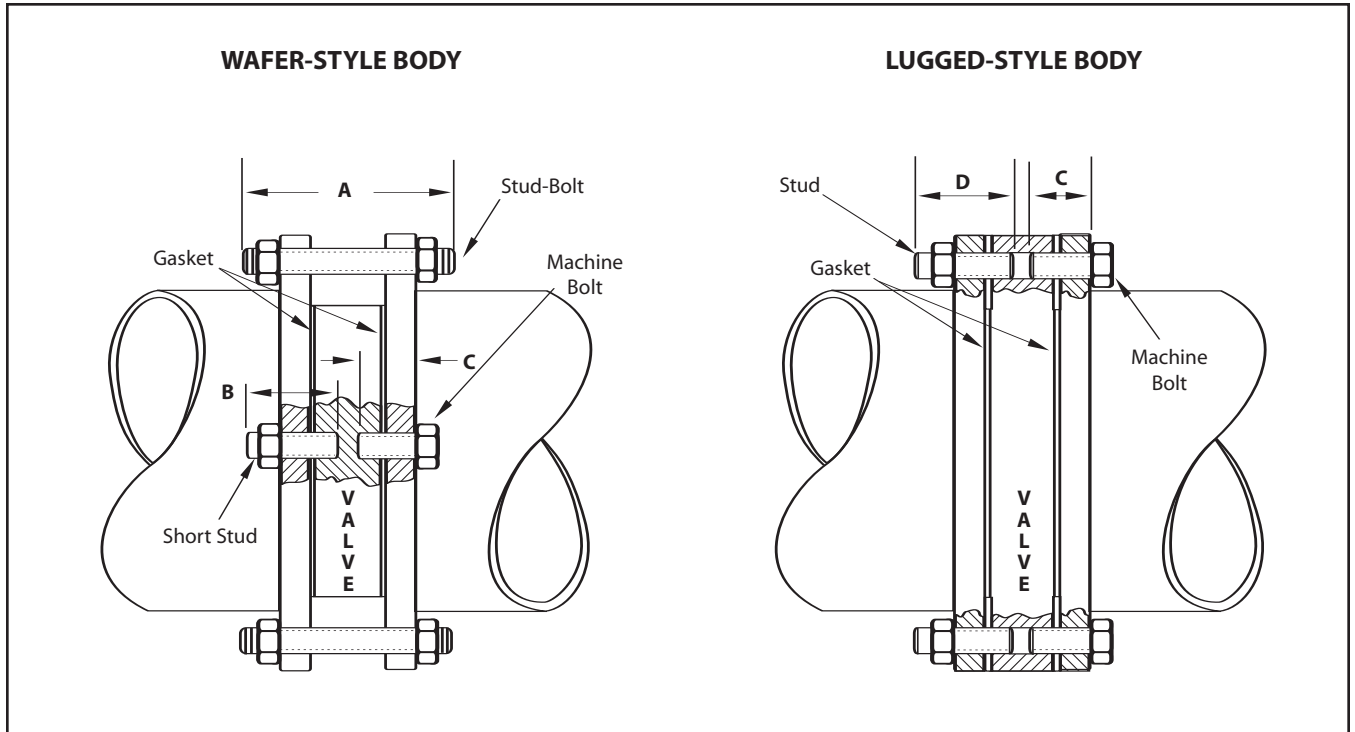

Valve Size		Fastener Diameter & Thread	Type 860W, Wafer Body					Type 860L, Lugged Body		
			Quantity		Length - inches			Quantity	Length - inches	
inches	DN		No. of "A" Stud-Bolts	No. of "B" Studs or "C" Machine Bolts	Stud-Bolt Length (A)	Short Stud Length (B)	Machine Bolt (C)	No. of "C" Machine Bolts or "D" studs	Machine Bolt Length (C)	Stud Length (D)
3	80	3/4"-10UNC	8	—	7	—	—	16	2-1/4	3-1/4
4	100	7/8"-9UNC	8	—	8-1/4	—	—	16	2-3/4	3-3/4
6	150	1"-8UNC	12	—	9-1/2	—	—	24	3-1/4	4-1/4
8	200	1-1/8"-8UN	12	—	11-1/4	—	—	24	3-3/4	5
10	250	1-1/4"-8UN	12	8	13	5-1/2	4-1/4	32	4-1/4	5-1/2
12	300	1-1/4"-8UN	16	8	14-1/4	5-1/2	4-1/4	40	4-1/4	5-1/2
14	350	1-3/8"-8UN	16	8	15-1/4	6	4-1/2	40	4-1/2	6
16	400	1-1/2"-8UN	16	8	16-1/2	6-1/2	5	40	5	6-1/2
18	450	1-5/8"-8UN	16	8	18-1/2	7	5-1/4	40	5-1/4	7
20	500	1-5/8"-8UN	20	8	19-1/2	7-1/4	5-3/4	48	5-3/4	7-1/4
24	600	1-7/8"-8UN	20	8	24	8-1/4	6-1/2	48	6-1/2	8-1/4

Valve Size		Fastener Diameter & Thread	Type 835L, Lugged Body (With flange holes drilled through, word modifier "DV")					Type 835L, Lugged Body		
			Quantity		Length - inches			Quantity	Length - inches	
inches	DN		No. of "A" Stud-Bolts	No. of "B" Studs or "C" Machine Bolts	Stud-Bolt Length (A)	Short Stud Length (B)	Machine Bolt (C)	No. of "C" Machine Bolts or "D" studs	Machine Bolt Length (C)	Stud Length (D)
30	750	1-1/4"-8UN	24	8	14	6	4-3/4	56	4-3/4	6
36	900	1-1/2"-8UN	28	8	17	7	5-1/2	64	5-1/2	7
40	1000	1-1/2"-8UN	32	8	19-1/2	7	5-1/2	72	5-1/2	7
42	1050	1-1/2"-8UN	32	8	20	7-1/4	5-3/4	72	5-3/4	7-1/4
48	1200	1-1/2"-8UN	40	8	21-1/2	7-3/4	6-1/4	88	6-1/4	7-3/4
54	1350	1-3/4"-8UN	40	8	24	8-3/4	7	88	7	8-3/4
60	1500	1-3/4"-8UN	48	8	25-1/2	9-1/4	7-1/2	104	7-1/2	9-1/4

Valve Size			Type 845W, Wafer Body				
			Quantity		Length – inches		
inches	DN	Fastener Diameter & Thread	No. of "A" Stud-Bolts	No. of "B" Studs or "C" Machine Bolts	Stud-Bolt Length (A)	Short Stud Length (B)	Machine Bolt (C)
10	250	7/8" – 9UNC	12	—	7-1/2	—	—
12	300	7/8" – 9UNC	12	—	8	—	—
14	350	1" – 8UNC	12	—	9	—	—
16	400	1" – 8UNC	16	—	9-1/2	—	—
18	450	1-1/8" – 8UN	16	—	10-1/2	—	—
20	500	1-1/8" – 8UN	16	8	11-1/2	4-1/2	3-1/4
24	600	1-1/4" – 8UN	16	8	13-1/4	4-3/4	3-1/2
28	700	1-1/4" – 8UN	24	8	15-1/2	5-3/4	4-1/2
30	750	1-1/4" – 8UN	24	8	15-3/4	6	4-1/2
32	800	1-1/2" – 8UN	24	8	17-1/2	6-3/4	5-1/4
36	900	1-1/2" – 8UN	28	8	18-1/2	7	5-1/2
42	1050	1-1/2" – 8UN	32	8	20-1/2	7-1/4	5-3/4

## Installation Instructions, Maintenance and Operation

IMO's (Installation, Maintenance, and Operating instructions) or AMI's (Assembly, Mounting, and Installation instructions) are shipped with the products. Additional copies of these instructions are available. Call your local Metso Automation Distributor, or visit our web site.

### Metso Automation, Field Systems Division

**Europe**, Levytie 6, P.O.Box 310, 00811 Helsinki, Finland. Tel. int. +358 20 483 150. Fax int. +358 20 483 151

**Europe (UK)**, 2 Lindenwood, Crockford Lane, Chineham Business Park, Basingstoke, RG24 8QY UK. Tel. int. +44 (0) 8706 061478. Fax int. +44 (0) 1256 707661

**North America**, 44 Bowditch Drive, P.O.Box 8044, Shrewsbury, Massachusetts, 01545-8044 USA. Tel. int. +1 508 852 0200. Fax int. +1 508 852 8172

**Latin America**, Av. Independência, 2500- Iporanga, 18087-101, Sorocaba-São Paulo, Brazil. Tel. int. +55 15 3235 9700. Fax int. +55 15 3235 9748/49

**Asia Pacific**, 501 Orchard Road, #05-09 Wheelock Place, 238880 Singapore. Tel. int. +65 735 5200. Fax int. +65 735 4566

[www.jamesbury.com](http://www.jamesbury.com)

